

ANGLE PLOW SCRAPER / IBL-AP-A

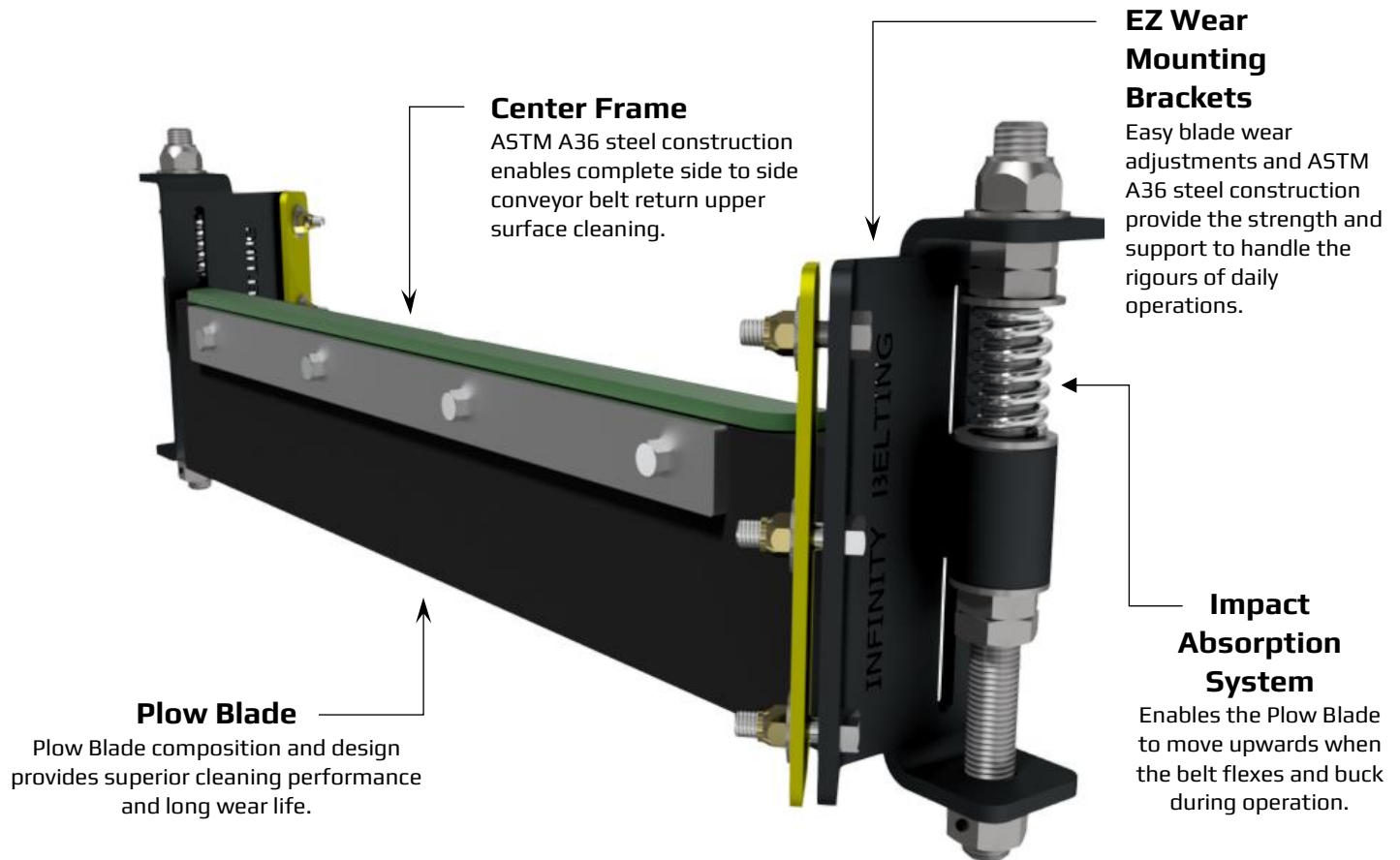

EXCEPTIONAL PERFORMANCE, LONG LASTING & DURABLE

Infinity Belting Ltd.'s Angle Plow Scrapers have been designed to keep your operation running by eliminating material build up on the belt return upper surface and tail pulley. The Angle Plow can be used in applications such as Agricultural, Bio-Mass, Forestry & anywhere that Bulk Handling Conveyor systems exist.



FEATURES AND BENEFITS:

- Plow Blade design conforms to the running belt surface ensuring adaptable surface contact without excessive pressure having to be applied.
- Patent pending Impact Absorption Mounting System (IAMS) provides fully adjustable blade to surface contact and impact reduction ensuring superior cleaning performance and zero belt damage.
- Infinity Belting Angle Plow's are available in all belt widths and can be installed on any style frame in the market.
- Rudimentary, compact design enables successful installation in restricted, tight locations within your conveyor system.
- Rock solid construction will give long term service in many applications.

FOR ORDERS AND SALES:

CALL: 1-780-963-3084 / Email: info@infinitybelting.com