

# CBOF - Conveyor Belt Order Form

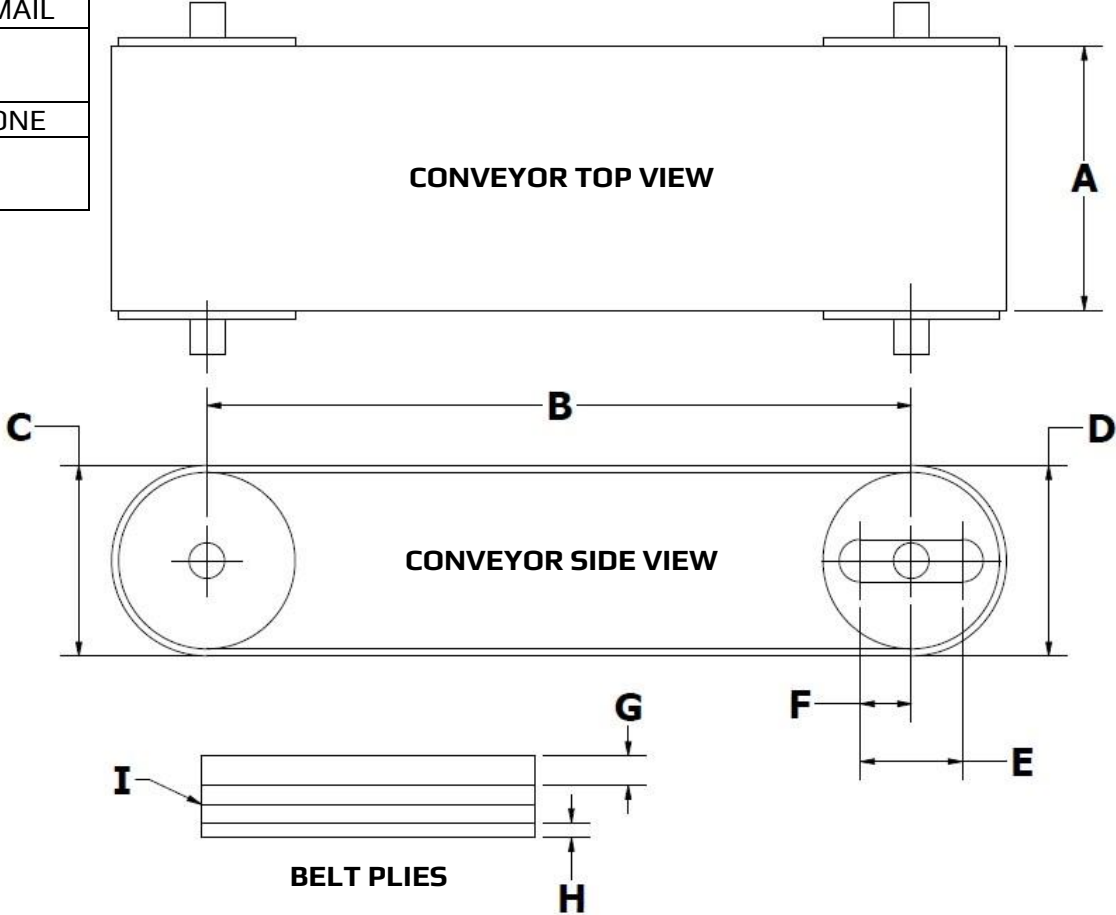

BELTING LTD

CUSTOMER	PLANT/UNIT No	MATERIAL	MAX LUMP SIZE	MIN LUMP SIZE
CUSTOMER EMAIL				
CUSTOMER PHONE				



MEASUREMENTS REQUIRED		FEET / INCHES	M / CM
A	BELT WIDTH		
B	HEAD PULLEY SHAFT CENTER TO TAIL PULLEY SHAFT CENTER		
C	HEAD PULLEY INCLUDING LAGGING		
D	TAIL PULLEY INCLUDING LAGGING		
E	TAKE UP GAP TO ACHIEVE MAXIMUM BELT TENSION		
F	TAKE UP GAP TO ACHIEVE MINIMUM BELT TENSION		
G	TOP LAYER THICKNESS		
H	BOTTOM LAYER THICKNESS		
I	NUMBER OF PLY		

Total Belt Length required - **ft** **inches**

PO Number: \_\_\_\_\_ - **m** **cm**

For all your Conveyor Belt Supply and Installation needs call Infinity Belting Ltd:  
**+1(780) 963-3084**